

## **Impact of Quantitative, Emotional, and Cognitive Job Demands on Work-to-Family Conflict of University Faculty in Pakistan**

**Farhan Sarwar**

University of Education

**Siti Aisyah Panatik**

Universiti Teknologi Malaysia Johar

University academic faculty in Pakistan are facing greater pressures and higher workload from their jobs. It was hypothesized that faculty face quantitative, cognitive, and emotional demands on their jobs which would positively impact their experience of conflict arising from work and affecting family roles. A sample of 425 public sector faculty member from Pakistan filled an online survey questionnaire. The questionnaire consisted of demographic information, Work to Family Conflict Scale-Short Form (Kacmar, Wayne, Carlson, Ferguson, & Whitten, 2014), and Job Demands Scale consisting of four items adopted by Experience and Evaluation of Work (Van Veldhoven & Meijman, 1994). Findings of *t*-test revealed that female faculty perceived significantly higher work-to-family conflict and cognitive demands compared to male faculty, while there was no gender difference in perceptions of quantitative and emotional demands. The hypothesized model was tested using structural equation modeling and a good fit was achieved. The direct relationship between quantitative and emotional job demands with work to the family conflict was significant and between cognitive job demands and work to family conflict was insignificant. No gender-based variance was found in the hypothesized model. The results can provide guidelines for the university administration to device effective work-family policies.

*Keywords:* quantitative demands, cognitive demands, emotional demands, work-family conflict, university faculty

---

Farhan Sarwar, Faculty of Economics and Business Administration, Township Campus, University of Education, Lahore, Pakistan.

Siti Aisyah Panatik, Faculty of Management, Universiti Teknologi Malaysia, Johor, Malaysia.

Correspondence concerning this article should be addressed to Farhan Sarwar, Faculty of Economics and Business Administration, Township Campus, University of Education, Lahore, Pakistan. E-mail: farhansarwar@ue.edu.pk

Work-family conflict is defined as a situation when role pressures in work domain or family domain make it difficult to participate in roles across the domain (Watanabe & Falci, 2014). It is a bi-directional phenomenon which gives rise to two distinct constructs, work-to-family conflict (W-FC) and family-to-work conflict (F-WC). As the name implies, W-FC occurs when factors at work domain negatively influence the family domain such that role participation gets difficult and performance is diminished in the latter domain (Zábrodská et al., 2017). Earlier research indicates that W-FC is more prevalent as compared to F-WC and is more strongly related to performance and wellbeing outcomes (Gatta & Roos, 2004). A study has established that conflict that originates from the work domain and influences family domain results in dysfunctional family relations and deteriorate health and wellbeing of employees (Mudrak et al., 2017). Earlier studies on university academic faculty found that experience of W-FC is most potent predictor of their burnout (see e.g., Zábrodská et al., 2017), reduced wellbeing (Winefield, Boyd, & Winefield, 2014) and relates negatively to faculty's perception of job satisfaction, family satisfaction, and life satisfaction (Pattusamy & Jacob, 2015).

Contemporary university faculty are facing greater job pressures and high workload compared to their counterparts a few decades ago (Zabrodská et al., 2017). According to Curtis (2004), university faculty's job is different from other professions. It is more of a dedicated mission that is driven by a sense of learning, curiosity, knowledge creation, and dissipation. The ideal worker norm exists in academia which compels faculty to remain more committed and dedicated to their profession over and above the family responsibilities (Wolf-Wendel & Ward, 2015). In Pakistan, advent of Higher Education Commission (HEC) to enhance the standard, quality, and outreach of higher education have also resulted in greater job pressures and higher workload of the university faculty (Parveen, Rashid, Iqbal, & Khan, 2011; Riaz, Jabeen, Salman, Ansari, & Moazzam, 2017). The situation gets worse in public sector universities, where HEC exercises more power. There is an excessive demand for a greater number of high impact factor publications and top standard teaching without providing ample resources putting more strain on university faculty in Pakistan (Mahmood, 2016; Yusoff & Khan, 2013). Therefore, the current research explores the antecedents of W-FC among public sector faculty in Pakistan.

There has been considerable supporting evidence in the existing literature regarding the positive influence of job demands on W-FC (Demerouti, Bakker, & Voydanoff, 2010; Peeters, Montgomery, Bakker, & Schaufeli, 2005). Three dimensions of job demands

including quantitative job demands, cognitive job demands, and emotional job demands are considered as three unique constructs. These three types of demands are found related to various occupational groups including university faculty (Bakker & Demerouti, 2007). Yet, extent faculty related research has operationalized job demands in terms of work overload. Little is known how emotional and cognitive work demands along with quantitative work demands uniquely affect faculty experience of work to family conflict. In addition, most work-family studies pertinent to higher education academics have been conducted in the Western context while scant research exists in the context of Pakistan's higher education. A study in South Asian culture characterized by collectivism, uncertainty avoidance, and restraint will augment new perspectives in existing work-family literature.

The current research would also help us to understand how negative job factors contribute to work-family issues which could prove prudent to higher education policymakers and faculty themselves to re-craft their jobs accordingly. Another unique contribution of this study is to understand the gender-based differences in perceptions of W-FC, demands and influence of gender on hypothesized relationships. Watanabe and Falci (2014) reported that women are more likely to leave higher education academia than men due to work-family balance issues and non-family friendly work environment. The culture of role segregation in which men are considered bread earners and women being homemakers still persists in Pakistan (Ali, 2013; Saleem & Ajmal, 2018). Past decades have seen a steady increase in women's professional workforce yet there is a big gender gap (Sarwar & Abbasi, 2013).

The domain-specific perspective of antecedents of work-family conflict indicates that factors influencing W-FC lie in the work domain (Frone, Yardley, & Markel, 1997). Similarly, demands as stressors are closely related to individual perception of inter-domain role conflict (Liu & Cheung, 2015; ten Brummelhuis & Bakker, 2012). The pressure to complete a task in a limited time frame beyond the sense of comfortability is referred to as *quantitative job demand*. For faculty, this means enhanced teaching workload, extra administrative duties, and research publication deadlines. It is also commonly termed as role overload. Tasks that require high level of sustained mental efforts such as research work, solving complex problems, and understanding new academic concepts refers to *cognitive demands*. Finally, *emotional job demands* occurs when individual face an emotionally draining situation at job such as

reprimand from supervisor or a potentially student in class (ten Brummelhuis & Bakker, 2012).

Considering the stressful and demanding nature of faculty triple work profile (Vera, Salanova, & Martín, 2010), numerous research findings indicates that contemporary faculty faces all three types of demands at their workplace (Curtis, 2004; Mudrak et al., 2017; Pillay & Abhayawansa, 2014; Torp, Lysfjord, & Midje, 2018; Watanabe & Falci, 2014; Zábrodská et al., 2017). Facing excessive workload and tasks that compels to either spend more time at work or carry out work-based tasks at home (quantitative demands) causes time-based conflict with family roles (Greenhaus & Beutell, 1985). A high level of mental activity (cognitive demands) can make induce mental fatigue leading to strain or behavioral issues at home (Ilies, Huth, Ryan, & Dimotakis, 2015). In the similar fashion, emotional encounters (emotional demands) at work that disturb mood for a longer period of time can negatively spillover to family roles yet again leading to role interference (Grzywacz & Marks, 2000).

The seminal study conducted by Peeters et al. (2005) in the USA with a large sample of professionals found a significant positive relationship of quantitative job demands, cognitive job demands, and emotional job demands with work-family interference. In another study on married medical residents, a significant positive relationship was found between these three types of demands and work-family interference. In a more recent study carried out in Italy on a heterogeneous sample of 617 employees, Molino, Bakker, and Ghislieri (2016) registered a highly positive correlation of WFC with workload and moderate correlation with cognitive demands and emotional demands. In both Peeters et al.'s (2005) and Molino et al.'s (2016) studies, the SEM analysis was conducted with job demands as a higher-order latent combination of three types of constructs in line with job demand resource model.

Although, job demands and friction between work and family domain is a problem for all university faculty, there is a mutual consensus that for female faculty members, the challenge of caring for a family and simultaneously managing substantial faculty workload is gigantic as they have greater share in fulfilling the home tasks and child upbringing (Misra, Lundquist, & Templer, 2012; Wolf-Wendel & Ward, 2015). It is observed that gender inequality still persists in academia albeit greater literary and public attention to raising women's status in university (Winslow & Davis, 2016). A research on 2229 faculty members with 43.9% women in the Czech Republic revealed that women reported higher levels of burnout, though, no significant gender difference was found in perceptions of W-FC. The

results of bivariate correlation in Torp et al.'s (2018) study on academicians in Norway indicated that women had a greater perception of W-FC than men, while no difference was found in job demands. Hogan, Hogan, Hodgins, Kinman, and Bunting (2014) found that female faculty in Norway reported a higher level of both job demands and work-life conflict compared to male faculty. By conducting gender-based variance analysis in the structural equation model, Peeters et al. (2005) study found that work-family interference was more strongly related to burnout for women than men, while no relationship existed in job demand and work-family interference. In Pakistan where extended families and patriarchal structure still exists, the burden to share the large responsibilities of house chores lies with women with extra responsibility of child rearing for married ones (Rehman & Roomi, 2012). Henceforth, keeping all the previous literature in mind, following hypotheses were formulated for the present study:

1. The faculty's W-FC will be positively and significantly predicted by quantitative job demands, cognitive job demands, and emotional job demands.
2. Female faculty members will report higher level of quantitative demands, cognitive demands, emotional demands, and W-FC as compared to male faculty members.

## **Method**

### **Participants and Procedure**

The population of the study was full time faculty members in Pakistan from public sector. At the time of this research, there were 109 public sector universities in Pakistan (Pakistan Education Statistics, 2018) of which 30 universities were randomly selected for further sampling. Email addresses were collected from the websites and 5450 emails were sent. All emails had an introductory note which introduced to the scope of research and an informed consent note and the survey which was based on demographics and adopted measures for study variables. The language for data collection was English. After a follow-up and reminder emails with one-week gap 462 responses were received. This depicts a response rate of 8.5% which is considered normal for data collection via the internet (Pattusamy & Jacob, 2015, 2016). Catering for missing values and inconsistent responses, 425 questionnaires were retained for final analysis. Among

the final sample 144 (33.9%) were women; 5(1.2%) were younger than 25 years old, 195(45.9%) 25-34 years, 170(40.0%) 35-44 years, 35(8.2%) 45-54years, and 20(4.7%) were 55 years or older; 333 (78.4%) of the respondents were married; 216 (50.8%) had Ph.D. degree; 193(45.4%) were lecturers, 196(46.1%) were assistant professors, 26 (6.1%) were associate professors, and 10(2.4%) were full professors.

## Measures

**Work to Family Conflict (W-FC).** W-FC was measured by a Work to Family Conflict Scale-Short Form having three-items (Kacmar et al., 2014). This scale was developed as an abridged form of Carlson, Kacmar, and Williams (2000) nine-item scales. Each item represents three types of conflicts including Strain-based, Time-based, and Behavioral-based as conceptualized by Greenhaus and Beutell (1985). A sample item is: "I have to miss family activities due to the amount of time I must spend on work responsibilities". The items are rated on a Likert scale ranging from 1 = *strongly disagree* to 5 = *strongly agree*. Higher values represented higher perception of conflict experienced by employees.

**Job Demands Scale.** Job demands were measured by items adopted from the English version of the Questionnaire on the Experience and Evaluation of Work by Van Veldhoven and Meijman (1994). It measures three dimensions of job demands. Quantitative Job Demands were represented by four items. A sample item is "how often it happens that you have to work very fast?". Emotional Job Demands were measured by four items of emotional load scale of the questionnaire. A sample item is "does your work demand a lot from you emotionally". Finally, Cognitive Job Demands were assessed by four items adapted from mental load scale. A sample item is "do you have to work with a lot of precision?". Responses were made on five-point scales with 1 = *never*, 2 = *sometimes*, 3 = *occasionally*, 4 = *often* and 5 = *always*.

**Demographic Information.** The demographic section of the survey consisted of gender, age, marital status, educational level, and designation. All these nominal and ordinal demographics scales were numerically coded and used as a control variable in the analysis.

## Results

Descriptive statistics, correlations, *t*-tests, and exploratory factor analysis were carried out in SPSS-24. Independent sample *t*-test was

used to confirm the gender differences. The relationship-based hypothesis was tested by covariance-based structural equation modeling (CB-SEM) in AMOS-24 (Torp et al., 2018).

The parameters were estimated using the maximum likelihood estimation method. The kurtosis and skewness of items in our data were between +1 and -1 (skewness between .15 to -.89 & kurtosis between .74 to -.92) indicating that it fulfills conditions for normality and can be subjected to CB-SEM. Generally, a complete SEM consists of two types of tests, measurement model test and structural model test. To test the overall fit of the model, following fit indices were used; Chi-Square ( $\chi^2$ ) goodness of fit statistics. Other fit indices used in this study are the  $\chi^2/df$ , comparative fit index (CFI), the goodness of fit index (GFI), the root mean square error of approximation (RMSEA). For  $\chi^2/df$  a value between 2 and 3 is considered acceptable, the acceptable values for CFI and GFI are greater than 0.90 and RMSEA lower than 0.08 is preferable (Hu & Bentler, 1999). The reliabilities of items for each latent variable were verified by Cronbach  $\alpha$  and composite reliability which should be greater than 0.70 to indicate sufficient internal consistency. Convergent validity was established by average variance extracted for which the cut-off criteria is 0.50 (Hair, Hollingsworth, Randolph, & Chong, 2017). Finally, discriminant validity was established by Fornell and Larcker (1981) criteria.

Table 1  
*Correlation Among Study Variables (N = 425)*

	<i>Mean</i>	<i>SD</i>	W-FC	QJD	CJD	EJD
W-FC	2.91	0.97	-			
QJD	3.45	0.88	.41*	-		
CJD	3.93	0.73	.25*	.54*	-	
EJD	3.01	0.85	.37*	.52*	.39*	-

*Note.* W-FC = work to family conflict; QJD = quantitative job demands; CJD = Cognitive job demands; EJD = emotional job demands.

\*  $p < .001$ .

Table 1 shows the bivariate Pearson correlation between W-FC and three types of job demands. The correlations between demand variables are significant and their magnitudes are from moderate to strong (.39 to .54). The correlation between W-FC and demand variables are also positive and moderate to strong (.25 to .41).

Table 2

*Gender Difference on Work-Family Conflict and Job Demands (N = 425)*

Variables	Men		Women		<i>t</i>	<i>p</i>
	(n = 281)		(n = 144)			
	<i>M</i>	<i>SD</i>	<i>M</i>	<i>SD</i>		
W-FC	2.83	0.95	3.07	0.98	-2.36	.01
QJD	3.40	0.90	3.53	0.85	-1.45	.14
CJD	3.88	0.77	4.02	0.65	-2.01	.04
EJD	3.00	0.83	3.03	0.89	-0.44	.66

*Note.* W-FC = work to family conflict; QJD = quantitative job demands; CJD = cognitive job demands; EJD = emotional job demands.

Table 2 shows that women experienced significantly higher W-FC and cognitive demands as compared to men, while there were nonsignificant difference in perceptions of quantitative and emotional demands.

The measurement model invariance with respect to gender was verified by means of confirmatory factor analysis (CFA). We ran the CFA in AMOS by selecting gender as a grouping variable. The hypothesized model proved to be an adequate fit,  $\chi^2(90) = 232.032$ ,  $p < .001$ ,  $\chi^2/df = 2.762$ , CFI = 0.943, RMSEA = 0.064, GFI = 0.931, which shows that the factor structure is equivalent across men and women. We also tested for measurement invariance with respect to gender by comparing unconstrained and constrained CFA models. The results of the Chi-Square difference test,  $\Delta\chi^2(28) = 20.047$ ,  $p = .80$ , also revealed invariance of the measurement model for multiple values of gender. Next, we analyzed the reliabilities and validities of the measurement model.

Table 3

*Reliability and Validity Values (N = 425)*

Variables	$\alpha$	CR	AVE	1	2	3	4
1. CJD	0.81	0.81	0.51	<b>0.71</b>			
2. W-FC	0.77	0.78	0.54	0.33	<b>0.73</b>		
3. QJD	0.86	0.87	0.62	0.66	0.49	<b>0.79</b>	
4. EJD	0.74	0.75	0.51	0.39	0.51	0.58	<b>0.72</b>

*Note.* CR = composite reliability; AVE = average variance extracted; CJD = cognitive job demands; W-FC = work to family; QJD = quantitative job demands; EJD = emotional job demands. Boldface values in diagonal represents the square root of average variance extracted.



As shown in Table 3, The Cronbach alpha and composite reliability values for all four measures are greater than .70. The AVE values for latent constructs are greater than the cutoff of 0.50 showing an evidence for convergent validity.

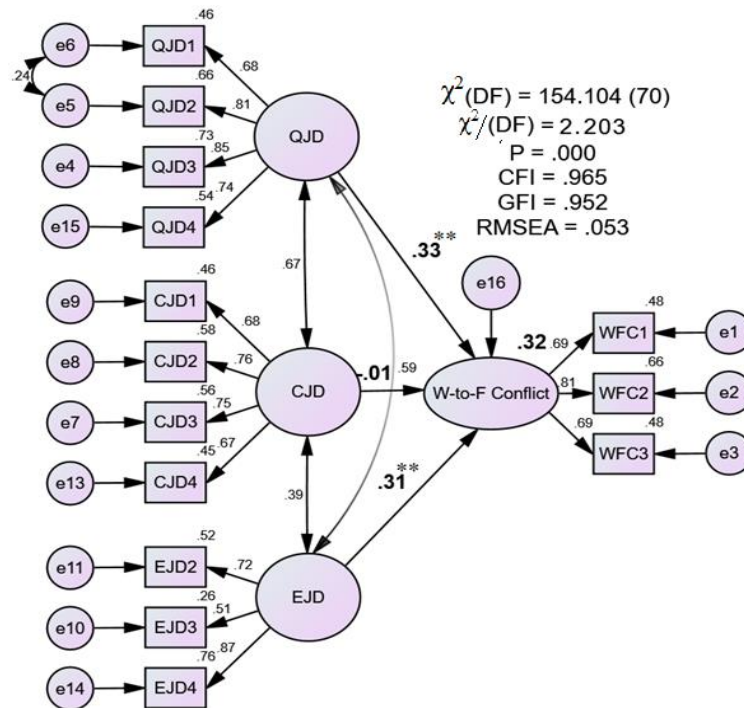

Figure 1. SEM structural model and results implemented in AMOS.

\*\*  $p < 0.01$ .

The structural model was based on hypothesized relationships in the study. From the results (Figure 1) it is evident that hypothesized model had a good fit with data;  $\chi^2(70) = 154.10$ ,  $p < .001$ ,  $CFI = .965$ ,  $GFI = .952$ ,  $RMSEA = .053$ . The coefficient of determination values ( $r^2$ ) was 0.32 which means exogenous variables accounted for 32% of the variation in W-FC as an endogenous variable. Mixed results were achieved for direct paths. Quantitative job demands ( $\beta = .33$ ,  $p < 0.001$ ) and emotional job demands ( $\beta = .31$ ,  $p < 0.001$ ) are significantly and positively related to W-FC. However, nonsignificant relationship exists between cognitive job demands and W-FC. Finally, we re-run the model for group analysis to determine if gender has any effect on the results of the structural model. The results revealed

nonsignificant difference between unconstrained and constrained model;  $\Delta\chi^2(13) = 16.97, p = .20$ . Similarly, nonsignificant variance was found when individual paths were a constraint. Thus, no gender-based difference existed in the effect of quantitative and emotional job demands on W-FC.

### Discussion

Our first hypothesis was to understand how three variants of job demands (quantitative, cognitive, & emotional) relate to faculty's experience of conflicts that arise from the work domain and interfere with roles in the family domain for public sector university faculty in Pakistan. This hypothesis was partially supported. Quantitative job demands significantly predicted W-FC which is in line with recent existing research findings for university faculty. For instance, the same findings with research on university faculty were reported by Záborská et al. (2017) from the Czech Republic; Nasurdin and O'Driscoll (2012) in Malaysia and New Zealand; and Mark and Smith (2012) in Australia. The positive relationship between emotional demands and W-FC confirms the results that were found in another profession where Ilies et al. (2015) reported that in a sample of school teachers, emotional fatigue was the main source of resource drain and direct predictor of work interfering with family. Recently Ghislieri, Gatti, Molino, and Cortese (2017) also found that emotional dissonance (a discrepancy between felt emotions & displayed emotions) was important in work-family interactions among nurses. It is more prevalent in people-oriented professions such as university teaching. The discrepancy between two types of emotions acts as a stressor and it might spillover in other life domains, causing a negative influence on role performance across the domain (Bakker & Demerouti, 2013). An interesting finding of our study is that despite a positive and significant zero-order correlation existed between cognitive job demands and W-FC, the relationship became insignificant in the full-scale structural model. These findings are in accordance with Ilies et al. (2015) study on school teachers in which cognitive fatigue did not significantly predict work-family conflict in the multiple regression analysis, though both constructs had a significant positive correlation. These findings indicate that quantitative and emotional job demands are largely responsible for faculty experiencing friction in their family lives due to work life. The activities that are primarily cognitive in nature do not pose such a threat.

Regarding gender differences, present findings revealed nonsignificant differences between men and women on perception of

three types of job demands except for cognitive job demands. It reveals that higher education academia in Pakistan does not have any apparent gender-based discrimination in work-related tasks and responsibilities. In addition, these work-place emotional stressors, in the same way, contribute to both gender's perceptions of work interfering with family as no gender-based variance was found in the relationship model. However, according to our results, female academicians had a slightly higher perception of cognitive demands as compared to their male counterparts. Although, this finding does not corroborate with previous research on cognitive abilities on women as they are found to score higher on verbal abilities, accuracy, fine motor skills, and perceptual speed which is a very crucial factor in teaching. Whereas, men are found to possess greater skills for working memory and mathematical abilities which are both important for teaching as well as research (Zaidi, 2010). However, research has also proven that the cognitive functioning of women shows greater variability in different stages of the menstrual cycle with a disadvantage in an attentional cognitive task during their postovulatory phase of the menstrual cycle (Upadhayay & Guragain, 2014). This can be a probable reason that women reported higher cognitive demands. Women faculty members also reported higher mean W-FC when compared to their male counterparts. This finding is not unexpected since the challenge of combining faculty jobs with family life is more difficult for women as they are held more responsible for housework and child care (Misra et al., 2012) especially, in male dominant and patriarchal societies like Pakistan (Ali, 2013). Therefore, women scoring high on the perception that their work roles are responsible for issues in their family role is expected in such cultures. Saleem and Ajmal (2018) suggested that women in academia should be provided greater workplace facilities (like childcare, flexi-time etc.) to compensate for the imbalance due to their traditional gender roles. Men either family members, colleagues or in general should be educated about women right to financial and social empowerment in our society.

## **Conclusion**

Work-family issues are important for the wellbeing and performance of faculty (Pattusamy & Jacob, 2015). Interference or conflict between both domains of life has been found to have a detrimental effect on various wellbeing and performance outcomes, so it was important to investigate how it is influenced by negative job factors. The findings of the existing study can prove fruitful for higher education policymakers to reshape job requirements and the working

environment of academia. It is somewhat interesting that although, academic work is more cognitive in nature, work overload and emotional pressures were more relevant predictors for faculty's work-family issues. However, this does not indicate that faculty do not have higher cognitive demands since its means score was higher than quantitative and emotional demands. We recommend that teachers should be more proactive in adopting dynamic teaching, research and learning techniques to diminish their cognitive demands. The use of learning and teaching techniques like Tarsia (Hao, 2019) or collaborative teaching methods (Adam, Yusof, & Hamdan, 2019) can significantly reduce teachers' cognitive workload in the classroom.

Future researchers should investigate how three demands affect the faculty's job performance and wellbeing at work as well as their overall satisfaction with work-family balance (Valcour, 2007). They should also investigate relationships between positive aspects of academic work and work-family interface (work-family enrichment) of university faculty in research studies. To attract more women faculty members in academia, we need an enhanced effort and tailored work environment that allows a greater balance between work and family lives and reduces their work-family pressures. A limitation of our research was to use cross-sectional data which could lead to common method bias. However, the results of Harman (1967) single factor test negated this limitation. Another limitation of the study was to collect data from public sector faculty members only. Further researchers should expand the research to the private sector as well. Collecting research data using a non-probability sampling method can also be a limitation of the study. However, in social science research use of a purposive sampling method is preferred to expand the knowledge and is recommended by many scholars when random sampling is a non-practical option. The external validity of a study doing non-random sampling is established when the study is theoretically strong, uses published measures and does not deviate much from existing findings (Calder, Phillips, & Tybout, 1982).

## References

- Adam, M. A., Yusof, S. M., & Hamdan, A. R. (2019). The effect of using the manual of collaborative teaching approach to mastering the basic standard of writing Malay language. *Journal of Research in Psychology, 1*(3), 10-12.
- Ali, F. (2013). A multi-level perspective on equal employment opportunity for women in Pakistan. *Equality, Diversity and Inclusion: An International Journal, 32*(3), 289-309.

- Bakker, A. B., & Demerouti, E. (2007). The job demands-resources model: State of the art. *Journal of Managerial Psychology*, 22(3), 309-328. doi:<https://doi.org/10.1108/02683940710733115>
- Bakker, A. B., & Demerouti, E. (2013). The spillover-crossover model. *New Frontiers in Work and Family Research*, 54-70.
- Calder, B. J., Phillips, L. W., & Tybout, A. M. (1982). The concept of external validity. *Journal of Consumer Research*, 9(3), 240-244. Retrieved from <https://www.jstor.org/stable/2488620>
- Carlson, D. S., Kacmar, K. M., & Williams, L. (2000). Construction and initial validation of a multidimensional measure of work-family conflict. *Journal of Vocational Behavior*, 56(2), 249-276. doi:<https://doi.org/10.1006/jvbe.1999.1713>
- Curtis, J. W. (2004). Balancing work and family for faculty: Why it's important. *Academe-bulletin of the AAUP*, 90(6), 21-23. doi:<https://doi.org/10.2307/40252701>
- Demerouti, E., Bakker, A. B., & Voydanoff, P. (2010). Does home life interfere with or facilitate job performance? *European Journal of Work and Organizational Psychology*, 19(2), 128-149. doi:<https://doi.org/10.1080/13594320902930939>
- Fornell, C., & Larcker, D. F. (1981). Structural equation models with unobservable variables and measurement error: Algebra and statistics. *Journal of Marketing Research*, 18(3), 382-388. doi:<https://doi.org/10.1177/002224378101800313>
- Frone, M. R., Yardley, J., & Markel, K. (1997). Developing and testing an integrative model of the work-family interface. *Journal of Vocational Behavior*, 50(2), 145-167. doi:<https://doi.org/10.1006/jvbe.1996.1577>
- Gatta, M. L., & Roos, P. A. (2004). Balancing without a net in academia: Integrating family and work lives. *Equal Opportunities International*, 23(3/4/5), 124-142. doi:<https://doi.org/10.1108/02610150410787765>
- Ghislieri, C., Gatti, P., Molino, M., & Cortese, C. G. (2017). Work-family conflict and enrichment in nurses: Between job demands, perceived organisational support and work-family backlash. *Journal of Nursing Management*, 25(1), 65-75. doi:<https://doi.org/10.1111/jonm.12442>
- Greenhaus, J. H., & Beutell, N. J. (1985). Sources of conflict between work and family roles. *Academy of Management Review*, 10(1), 76-88. doi:<https://doi.org/10.2307/258214>
- Grzywacz, J., & Marks, N. (2000). Reconceptualizing the work-family interface: An ecological perspective on the correlates of positive and negative spillover between work and family. *Journal of Occupational Health Psychology*, 5(1), 111-126. doi:<https://doi.org/10.1037/1076-8998.5.1.111>

- Hair, J. F., Hollingsworth, C. L., Randolph, A. B., & Chong, A. Y. L. (2017). An updated and expanded assessment of PLS-SEM in information systems research. *Industrial Management & Data Systems*, *117*(3), 442-458. doi:<https://doi.org/10.1108/imds-04-2016-0130>
- Hao, C. C. (2019). Incorporating Tarsia to foster student collaboration in the mathematics classroom. *Journal of Research in Psychology*, *1*(3), 8-9.
- Harman, D. (1967). A single factor test of common method variance. *Journal of Psychology*, *35*, 359-378.
- Hogan, V., Hogan, M., Hodgins, M., Kinman, G., & Bunting, B. (2014). An examination of gender differences in the impact of individual and organisational factors on work hours, work-life conflict and psychological strain in academics. *The Irish Journal of Psychology*, *35*(2-3), 133-150.
- Hu, L., & Bentler, P. M. (1999). Cutoff criteria for fit indexes in covariance structure analysis: Conventional criteria versus new alternatives. *Structural Equation Modeling: A Multidisciplinary Journal*, *6*(1), 1-55. doi:<https://doi.org/10.1080/10705519909540118>
- Ilies, R., Huth, M., Ryan, A. M., & Dimotakis, N. (2015). Explaining the links between workload, distress, and work-family conflict among school employees: Physical, cognitive, and emotional fatigue. *Journal of Educational Psychology*, *107*(4), 1-14. doi:<http://dx.doi.org/10.1037/edu0000029>
- Kacmar, K. M., Wayne, J. H., Carlson, D. S., Ferguson, M., & Whitten, D. (2014). A short and valid measure of work-family enrichment. *Journal of Occupational Health Psychology*, *19*(1), 32-45. doi:<https://doi.org/10.1037/a0035123>
- Liu, H., & Cheung, F. M. (2015). The role of work-family role integration in a job demands-resources model among Chinese secondary school teachers. *Asian Journal of Social Psychology*, *18*(4), 288-298. doi:<https://doi.org/10.1111/ajsp.12103>
- Mahmood, K. (2016). *Overall Assessment of the higher education sector: Higher education commission, Islamabad, Pakistan*. Retrieved from <http://hec.gov.pk/english/universities/projects/>
- Mark, G., & Smith, A. P. (2012). Effects of occupational stress, job characteristics, coping, and attributional style on the mental health and job satisfaction of university employees. *Anxiety, Stress, & Coping*, *25*(1), 63-78.
- Misra, J., Lundquist, J. H., & Templer, A. (2012). Gender, work time, and care responsibilities among faculty. *Sociological Forum*, *27*(2), 300-323.
- Molino, M., Bakker, A. B., & Ghislieri, C. (2016). The role of workaholism in the job demands-resources model. *Anxiety, Stress, & Coping*, *29*(4), 400-414. doi:<http://dx.doi.org/10.1080/10615806.2015.1070833>

- Mudrak, J., Zabrodska, K., Kveton, P., Jelinek, M., Blatny, M., Solcova, I., & Machovcova, K. (2017). Occupational well-being among university faculty: A job demands-resources model. *Research in Higher Education, 59*(3), 325-348. doi:<https://doi.org/10.1007/s11162-017-9467-x>
- Nasurdin, A. M., & O'Driscoll, M. P. (2012). Work overload, parental demand, perceived organizational support, family support, and work-family conflict among New Zealand and Malaysian academics. *New Zealand Journal of Psychology, 41*(1), 38-48. doi:<https://doi.org/10.1108/cms-07-2017-0211>
- Parveen, A., Rashid, K., Iqbal, M. Z., & Khan, S. (2011). System and reforms of higher education in Pakistan. *International Journal of Business and Social Science, 2*(20), 260-267.
- Pattusamy, M., & Jacob, J. (2015). A test of Greenhaus and Allen (2011) model on work-family balance. *Current Psychology, 36*(2), 193-202. doi:<https://doi.org/10.1007/s12144-015-9400-4>
- Pattusamy, M., & Jacob, J. (2016). The mediating role of family-to-work conflict and work-family balance in the relationship between family support and family satisfaction: A three path mediation approach. *Current Psychology, 36*(4), 812-822. doi:<https://doi.org/10.1007/s12144-016-9470-y>
- Peeters, M. C., Montgomery, A., Bakker, A. B., & Schaufeli, W. B. (2005). Balancing work and home: How job and home demands are related to burnout. *International Journal of Stress Management, 12*(1), 43-61. doi:<https://doi.org/10.1037/1072-5245.12.1.43>
- Pakistan Education Statistics. (2018). *Pakistan education statistics (2016-17)*. Islamabad: Premier Printers. Retrieved from <http://library.aepam.edu.pk/Books/Pakistan%20Education%20Statistics%202016-17.pdf>
- Pillay, S., & Abhayawansa, S. (2014). Work-family balance: Perspectives from higher education. *Higher Education, 68*(5), 669-690. doi:<https://doi.org/10.1007/s10734-014-9738-9>
- Rehman, S., & Roomi, M. A. (2012). Gender and work-life balance: A phenomenological study of women entrepreneurs in Pakistan. *Journal of Small Business and Enterprise Development, 19*(2), 209-228.
- Riaz, H., Jabeen, N., Salman, Y., Ansari, N., & Moazzam, A. (2017). A study of higher education reforms in Pakistan: Key reforms and drivers. *Journal of the Research Society of Pakistan, 54*(2), 79-94.
- Saleem, G., & Ajmal, M. A. (2018). Work-family balance: Experiences of successful professional women in academia in Pakistan. *Pakistan Journal of Psychological Research, 33*(1), 101-121.
- Sarwar, F., & Abbasi, A. S. (2013). An In-depth analysis of women's labor force participation in Pakistan. *Middle-East Journal of Scientific Research, 15*(2), 208-215.

- ten Brummelhuis, L. L., & Bakker, A. B. (2012). A resource perspective on the work-home interface: The work-home resources model. *American Psychologist, 67*(7), 545-556. doi:<https://doi.org/10.1002/hrdq.21119>
- Torp, S., Lysfjord, L., & Midje, H. H. (2018). Workaholism and work-family conflict among university academics. *Higher Education, 76*(6), 1071-1090. doi:<https://doi.org/10.1007/s10734-018-0247-0>
- Upadhayay, N., & Guragain, S. (2014). Comparison of cognitive functions between male and female medical students: A pilot study. *Journal of Clinical and Diagnostic Research, 8*(6), BC12-BC15.
- Valcour, M. (2007). Work-based resources as moderators of the relationship between work hours and satisfaction with work-family balance. *Journal of Applied Psychology, 92*(6), 1-12. doi:<https://doi.org/10.1037/0021-9010.92.6.1512>
- Van Veldhoven, M., & Meijman, T. (1994). *Questionnaire on the experience and assessment of work: Preliminary English version*. Brussels: Amsterdam National Research Institute for Working Conditions.
- Vera, M., Salanova, M., & Martín, B. (2010). University faculty and work-related well-being: The importance of the triple work profile. *Electronic Journal of Research in Educational Psychology, 8*(2), 581-602. doi:<https://doi.org/10.25115/ejrep.v8i21.1373>
- Watanabe, M., & Falci, C. D. (2014). A demands and resources approach to understanding faculty turnover intentions due to work-family balance. *Journal of Family Issues, 37*(3), 393-415. doi:<https://doi.org/10.1177/0192513X14530972>
- Winefield, H. R., Boyd, C., & Winefield, A. H. (2014). Work-family conflict and well-being in university employees. *The Journal of Psychology, 148*(6), 683-697. doi:<http://dx.doi.org/10.1080/00223980.2013.822343>
- Winslow, S., & Davis, S. N. (2016). Gender inequality across the academic life course. *Sociology Compass, 10*(5), 404-416. doi:<https://doi.org/10.1111/soc4.12372>
- Wolf-Wendel, L., & Ward, K. (2015). Academic mothers: Exploring disciplinary perspectives. *Innovative Higher Education, 40*(1), 19-35.
- Yusoff, R. M., & Khan, F. (2013). Stress and burnout in the higher education sector in Pakistan: A systematic review of literature. *Research Journal of Recent Sciences, 2*(11), 90-98.
- Zabrodska, K., Mudrak, J., Kveton, P., Blatný, M., Machovcova, K., & Solcova, I. (2016). Keeping marketisation at bay: The quality of academic worklife in Czech universities. *Sociologicky Casopis/Czech Sociological Review, 52*(3), 347-374. doi:<https://doi.org/10.13060/00380288.2016.52.3.262>
- Zábrodská, K., Mudrák, J., Šolcová, I., Květon, P., Blatný, M., & Machovcová, K. (2017). Burnout among university faculty: The central



role of work-family conflict. *Educational Psychology*, 38(6), 800-819.  
doi:<http://dx.doi.org/10.1080/01443410.2017.1340590>

Zaidi, Z. F. (2010). Gender differences in human brain: A review. *The Open Anatomy Journal*, 2(1), 37-55.

Received 16<sup>th</sup> August, 2018

Revision received 23<sup>rd</sup> January, 2020